

BV <sub>DSS</sub>	-40V
R <sub>DS(ON)</sub>	40mΩ
I <sub>D</sub>	-6A

**P-CHANNEL ENHANCEMENT MODE POWER MOSFET**
**Description**

The BP9563 provide the designer with the best combination of fast switching, ruggedized device design, low on-resistance and cost-effectiveness.

The SOT-223 package is universally preferred for all commercial-industrial surface mount applications and suited for low voltage application such as DC/DC converters.

**Features**

- \*Simple Drive Requirement
- \*Lower On-resistance
- \*Fast Switching Characteristic

**Package Dimensions**

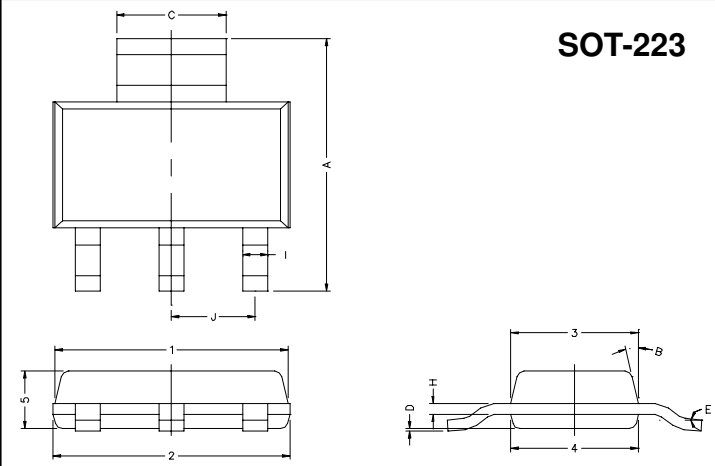

**SOT-223**

Marking :

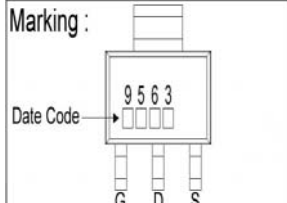
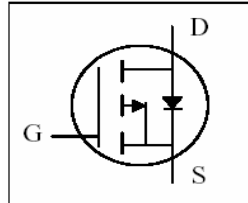
REF.	Millimeter		REF.	Millimeter	
	Min.	Max.		Min.	Max.
A	6.70	7.30	B	13°TYP.	
C	2.90	3.10	J	2.30 REF.	
D	0.02	0.10	1	6.30	6.70
E	0°	10°	2	6.30	6.70
I	0.60	0.80	3	3.30	3.70
H	0.25	0.35	4	3.30	3.70
			5	1.40	1.80

**Absolute Maximum Ratings**

Parameter	Symbol	Ratings	Unit
Drain-Source Voltage	V <sub>DS</sub>	-40	V
Gate-Source Voltage	V <sub>GS</sub>	±25	V
Continuous Drain Current <sup>3</sup>	I <sub>D</sub> @TA=25°C	-6	A
Continuous Drain Current <sup>3</sup>	I <sub>D</sub> @TA=70°C	-4.8	A
Pulsed Drain Current <sup>1</sup>	I <sub>DM</sub>	-30	A
Total Power Dissipation	P <sub>D</sub> @TA=25°C	2.7	W
Linear Derating Factor		0.02	W/°C
Operating Junction and Storage Temperature Range	T <sub>J</sub> , T <sub>stg</sub>	-55 ~ +150	°C

**Thermal Data**

Parameter	Symbol	Value	Unit
Thermal Resistance Junction-ambient <sup>3</sup> Max.	R <sub>thj-a</sub>	50	°C/W

## Electrical Characteristics (T<sub>j</sub> = 25°C unless otherwise specified)

Parameter	Symbol	Min.	Typ.	Max.	Unit	Test Conditions
Drain-Source Breakdown Voltage	BV <sub>DSS</sub>	-40	-	-	V	V <sub>GS</sub> =0, I <sub>D</sub> =-250uA
Breakdown Voltage Temperature Coefficient	ΔBV <sub>DSS</sub> /ΔT <sub>j</sub>	-	-0.03	-	V/°C	Reference to 25°C, I <sub>D</sub> =-1mA
Gate Threshold Voltage	V <sub>GS(th)</sub>	-1.0	-	-3.0	V	V <sub>DS</sub> =V <sub>GS</sub> , I <sub>D</sub> =-250uA
Forward Transconductance	g <sub>fs</sub>	-	10	-	S	V <sub>DS</sub> =-10V, I <sub>D</sub> =-6A
Gate-Source Leakage Current	I <sub>GSS</sub>	-	-	±100	nA	V <sub>GS</sub> = ±25V
Drain-Source Leakage Current(T <sub>j</sub> =25°C)	I <sub>DSS</sub>	-	-	-1	uA	V <sub>DS</sub> =-40V, V <sub>GS</sub> =0
Drain-Source Leakage Current(T <sub>j</sub> =70°C)		-	-	-25	uA	V <sub>DS</sub> =-32V, V <sub>GS</sub> =0
Static Drain-Source On-Resistance <sup>2</sup>	R <sub>DS(ON)</sub>	-	-	40	m	V <sub>GS</sub> =-10V, I <sub>D</sub> =-6A
		-	-	60		V <sub>GS</sub> =-4.5V, I <sub>D</sub> =-4A
Total Gate Charge <sup>2</sup>	Q <sub>g</sub>	-	19	30	nC	I <sub>D</sub> =-6A V <sub>DS</sub> =-32V V <sub>GS</sub> =-4.5V
Gate-Source Charge	Q <sub>gs</sub>	-	5	-		
Gate-Drain ("Miller") Charge	Q <sub>gd</sub>	-	8	-		
Turn-on Delay Time <sup>2</sup>	T <sub>d(on)</sub>	-	12	-	ns	V <sub>DS</sub> =-20V I <sub>D</sub> =-1A V <sub>GS</sub> =-10V R <sub>G</sub> =3.3 R <sub>D</sub> =20
Rise Time	T <sub>r</sub>	-	7	-		
Turn-off Delay Time	T <sub>d(off)</sub>	-	68	-		
Fall Time	T <sub>f</sub>	-	38	-		
Input Capacitance	C <sub>iss</sub>	-	1600	2560	pF	V <sub>GS</sub> =0V V <sub>DS</sub> =-25V f=1.0MHz
Output Capacitance	C <sub>oss</sub>	-	240	-		
Reverse Transfer Capacitance	C <sub>rss</sub>	-	190	-		

## Source-Drain Diode

Parameter	Symbol	Min.	Typ.	Max.	Unit	Test Conditions
Forward On Voltage <sup>2</sup>	V <sub>SD</sub>	-	-	-1.2	V	I <sub>S</sub> =-2A, V <sub>GS</sub> =0V
Reverse Recovery Time <sup>2</sup>	T <sub>rr</sub>	-	37	-	ns	I <sub>S</sub> =-6A, V <sub>GS</sub> =0V
Reverse Recovery Charge	Q <sub>rr</sub>	-	54	-	nC	dI/dt=100A/μs

Notes: 1. Pulse width limited by Max. junction temperature.

2. Pulse width ≤ 300us, duty cycle ≤ 2%.

3. Surface mounted on 1 in<sup>2</sup> copper pad of FR4 board; 120°C/W when mounted on Min. copper pad.

**Characteristics Curve**

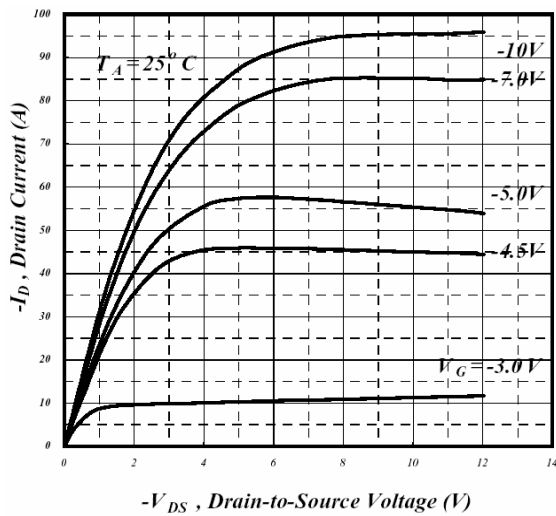

**Fig 1. Typical Output Characteristics**

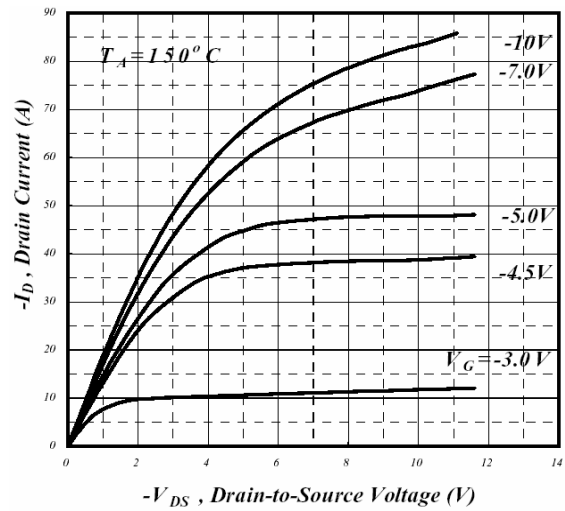

**Fig 2. Typical Output Characteristics**

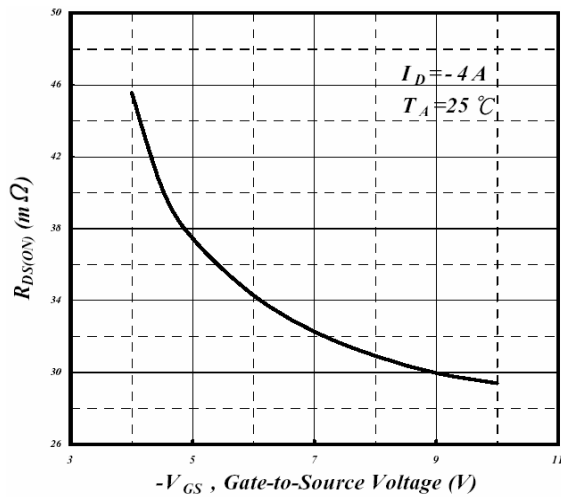

**Fig 3. On-Resistance v.s. Gate Voltage**

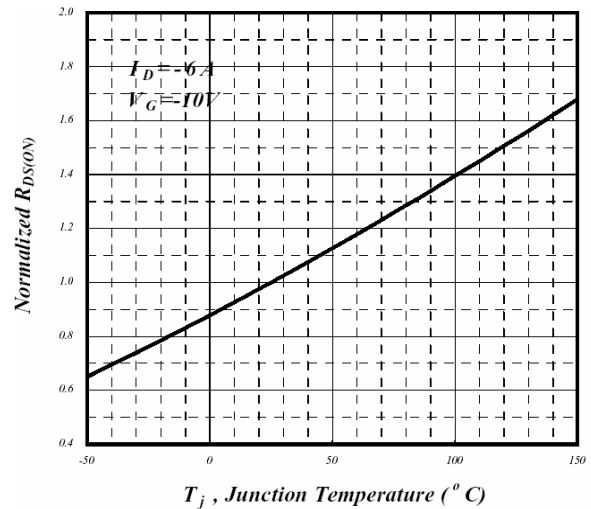

**Fig 4. Normalized On-Resistance v.s. Junction Temperature**

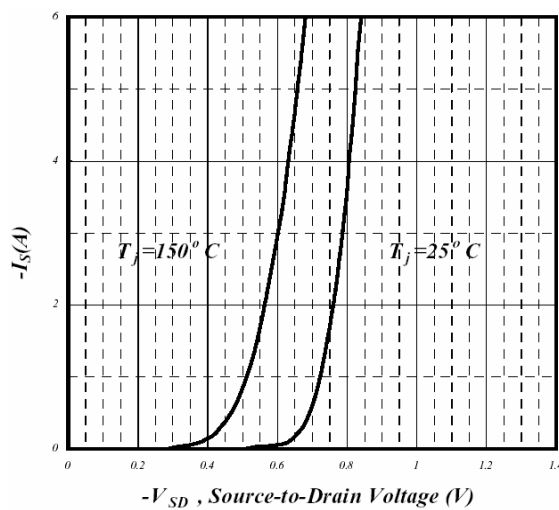

**Fig 5. Forward Characteristics of Reverse Diode**

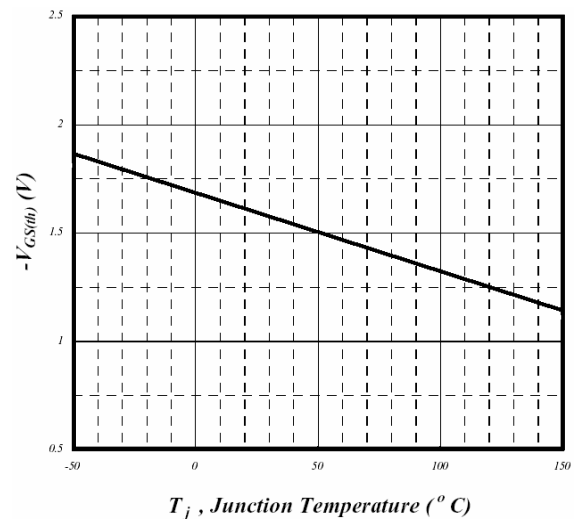

**Fig 6. Gate Threshold Voltage v.s. Junction Temperature**

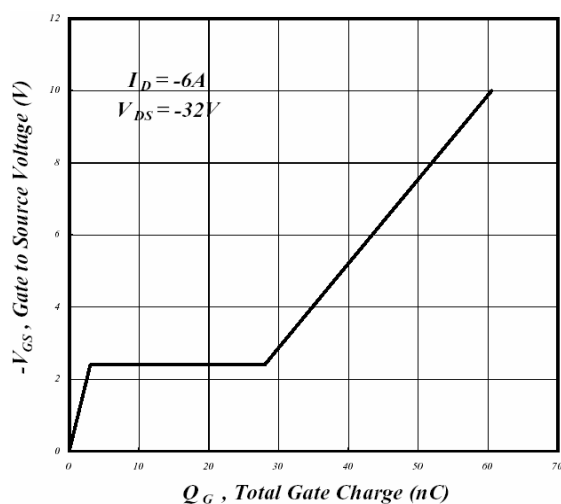

**Fig 7. Gate Charge Characteristics**

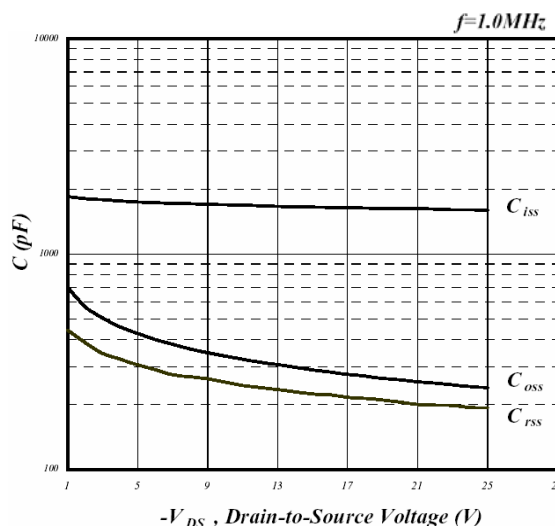

**Fig 8. Typical Capacitance Characteristics**

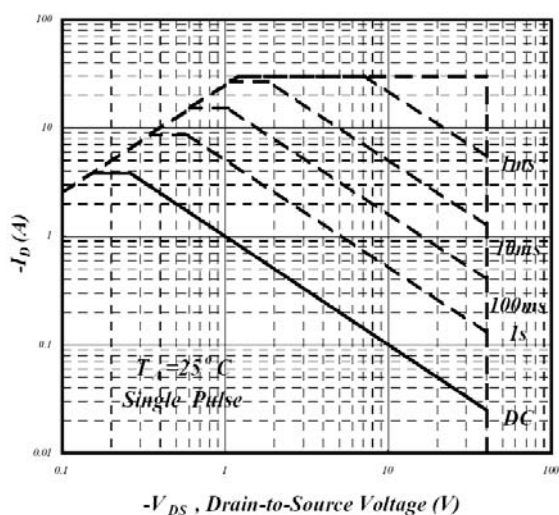

**Fig 9. Maximum Safe Operating Area**

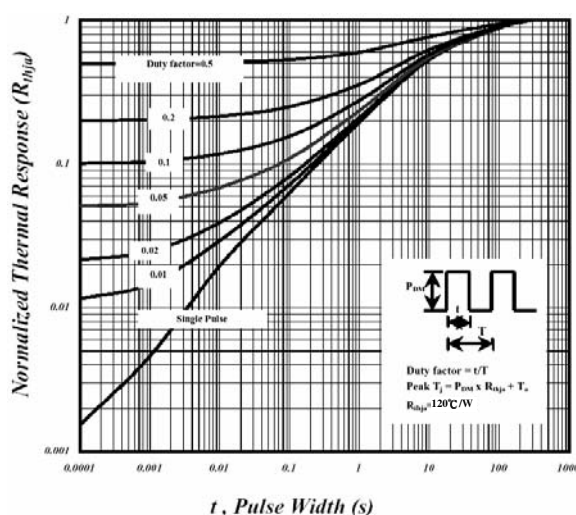

**Fig 10. Effective Transient Thermal Impedance**

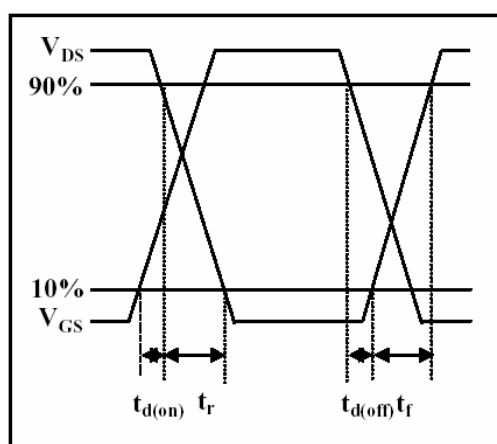

**Fig 11. Switching Time Waveform**

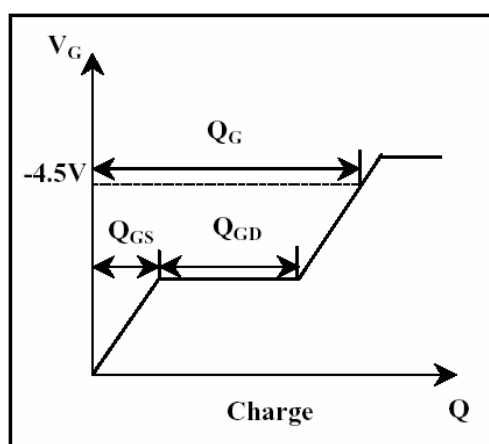

**Fig 12. Gate Charge Waveform**