

## General Description

The BP3289 is a charge pump voltage converter that delivers a regulated output. No external inductor is required for operation. Using three small capacitors, the BP3289 can deliver up to 60mA to the voltage regulated output. The BP3289 features very low output ripple and high efficiency over a large portion of its load range making this device ideal for battery-powered applications. Furthermore, the combination of few external components and small package size keep the total converter board area to a minimum in space restricted applications.

The BP3289 contains a thermal management circuit to protect the device under continuous output short circuit conditions.

The BP3289 is available in SOT-26 package and is rated from -40°C to 85°C.

## Features

- Output Voltage Range:  
5.5V, 5V, 3.3V, 3.0V, 2.7V, 2.5V
- Accurate to with  $\pm 5\%$
- 1MHz<sub>z</sub> Switching Frequency
- Shutdown Supply Current < 1 $\mu$ A
- Short Circuit Protection: Typ. 80mA
- Over Temperature Protection
- All our Lead Free Product Meet RoHS Standards

## Applications

- Cellular Phone
- Digital Camera
- PDAs LCD display
- LED/Display Back Light Driver
- Smart Card Reader
- SIM Card Supply
- PCMCIA Card
- LCD Display

## Functional Block Diagram

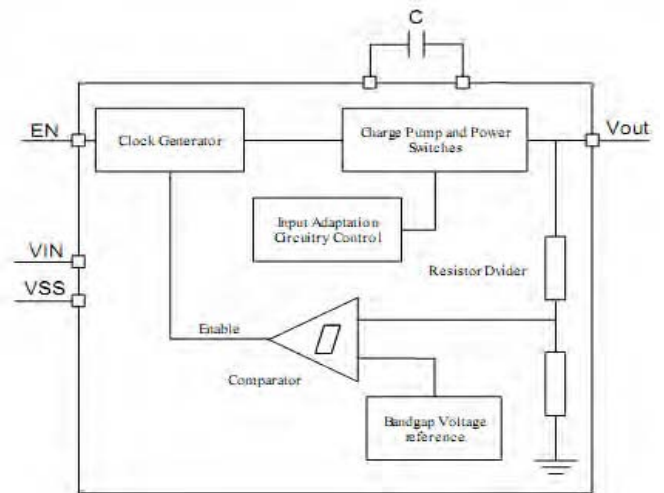

## Typical Application

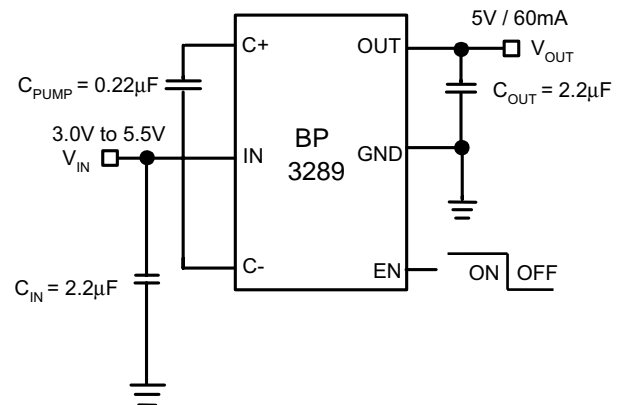

# BP3289

## ■ Pin Configuration

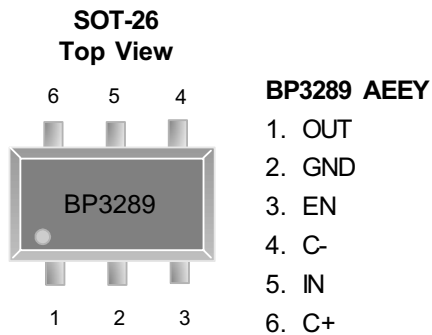

\* Die Attach:  
Conductive Epoxy

## ■ Pin Description

Pin Number	Pin Name	Description
1	OUT	Regulator Output Pin. $V_{OUT}$ should be bypassed with a 2.2 $\mu$ F low ESR ceramic capacitor.
2	GND	Ground Pin Connection.
3	EN	Enable Input. Active Low disable the regulator.
4	C-	Pump Capacitor Negative Terminal.
5	IN	Input Supply Pin. $V_{IN}$ should be bypassed with a 2.2 $\mu$ F low ESR ceramic capacitor.
6	C+	Pump Capacitor Positive Terminal.

# BP3289

## ■ Ordering Information

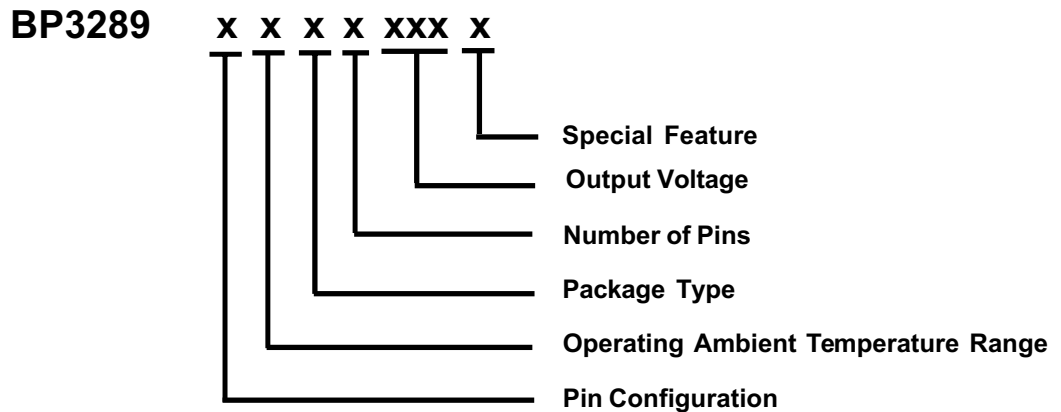

Pin Configuration	Operating Ambient Temperature Range	Package Type	Number of Pins	Output Voltage	Special Feature
A 1. OUT (SOT-26) 2. GND 3. EN 4. C- 5. IN 6. C+	E: -40°C to 85°C	E: SOT-2X	Y: 6	330: V=3.3V 500: V=5V 550: V=5.5V	Z: Lead free

## ■ Ordering Information

Part Number	Marking*	Output Voltage	Package	Operating Ambient Temperature Range
BP3289AEEY330Z	BJFww	3.3V	SOT-26	- 40°C to 85°C
BP3289AEEY500Z	BENww	5V	SOT-26	- 40°C to 85°C
BP3289AEEY550Z	BDWww	5.5V	SOT-26	- 40°C to 85°C

Note: ww represents the date code and pls refer to Date Code Rule before Package Dimension.

\* A line on top of the first letter represents lead free plating such as B̄JFww.

Please consult WW sales office or authorized Rep./Distributor for the availability of package type.

# BP3289

## ■ Absolute Maximum Ratings

Parameter	Maximum	Unit
Input Voltage, Output Voltage, C-, C+	-0.3~5.5	V
EN	-0.3~ $V_{IN} + 0.3$	

Note: Caution: Stress above the listed absolute maximum rating may cause permanent damage to the device.

## ■ Recommended Operating Conditions

Parameter	Symbol	Rating	Unit
Ambient Temperature Range	$T_A$	- 40 to 85	°C
Junction Temperature Range	$T_J$	- 40 to 125	°C
Storage Temperature Range	$T_{STG}$	- 65 to 150	°C

## ■ Thermal Information

Parameter	Package	Die Attach	Symbol	Maximum	Unit
Thermal Resistance* (Junction to Case)	SOT-26	Conductive Epoxy	$\theta_{JC}$	81	°C/W
Thermal Resistance (Junction to Ambient)			$\theta_{JA}$	260	
Internal Power Dissipation			$P_D$	400	mW
Maximum Junction Temperature				150	°C
Solder Iron (10 Sec)**				350	°C

\* Measure  $\theta_{JC}$  on backside center of molding compound if IC has no tab.

\*\* MIL-STD-202G 210F

# BP3289

## ■ Electrical Specifications (Contd.)

$T_A = -40^{\circ}\text{C}$  to  $85^{\circ}\text{C}$ ,  $V_{IN} = V_{OUT}/2 + 0.75\text{V}$ ,  $I_{OUT} = 5\text{mA}$ ,  $C_{IN} = 2.2\mu\text{F}$ ,  $C_{OUT} = 2.2\mu\text{F}$ ,  $C_{PUMP} = 0.22\mu\text{F}$ ,  $V_{EN} = 1.3\text{V}$   
 Typical Values are at  $T_A = 25^{\circ}\text{C}$

Parameter	Symbol	Test Conditions	Min	Typ	Max	Units
Input Voltage	$V_{IN}$	$V_{OUT} = 5.5\text{V}$	3		5.5	V
		$V_{OUT} = 5\text{V}$	2.7		5.5	
		$V_{OUT} = \text{Others}$	1.8		5.5	
Output Voltage	$V_{OUT}$	$I_{OUT} \leq 60\text{mA}$ , $3.3\text{V} < V_{IN} < 5.5\text{V}$	5.23	5.5	5.77	V
		$I_{OUT} \leq 15\text{mA}$ , $2.7\text{V} < V_{IN} < 5.5\text{V}$	4.75	5	5.25	
		$I_{OUT} \leq 60\text{mA}$ , $3.0\text{V} < V_{IN} < 5.5\text{V}$				
		$I_{OUT} \leq 15\text{mA}$ , $1.8\text{V} < V_{IN} < 5.5\text{V}$	3.14	3.3	3.46	
		$I_{OUT} \leq 60\text{mA}$ , $2.2\text{V} < V_{IN} < 5.5\text{V}$				
		$I_{OUT} \leq 15\text{mA}$ , $1.8\text{V} < V_{IN} < 5.5\text{V}$	2.85	3	3.15	
		$I_{OUT} \leq 60\text{mA}$ , $2.2\text{V} < V_{IN} < 5.5\text{V}$				
		$I_{OUT} \leq 15\text{mA}$ , $1.8\text{V} < V_{IN} < 5.5\text{V}$	2.57	2.7	2.83	
		$I_{OUT} \leq 60\text{mA}$ , $2.0\text{V} < V_{IN} < 5.5\text{V}$				
		$I_{OUT} \leq 15\text{mA}$ , $1.8\text{V} < V_{IN} < 5.5\text{V}$	2.38	2.5	2.62	
$I_{OUT} \leq 60\text{mA}$ , $2.0\text{V} < V_{IN} < 5.5\text{V}$						
Quiescent Current	$I_Q$	$3\text{V} < V_{IN} < 5.5\text{V}$ , $I_{OUT} = 0\text{mA}$ , $V_{OUT} = 5.5\text{V}$		60	100	$\mu\text{A}$
		$2.7\text{V} < V_{IN} < 5.5\text{V}$ , $I_{OUT} = 0\text{mA}$ , $V_{OUT} = 5\text{V}$				
		$1.8\text{V} < V_{IN} < 5.5\text{V}$ , $I_{OUT} = 0\text{mA}$ , $V_{OUT} = \text{Others}$				
Shutdown Current	$I_{SHDN}$	$1.8\text{V} < V_{IN} < 5.5\text{V}$ , $V_{EN} = \text{GND}$		0.01	1	
Output Current	$I_{OUT}$	$V_{OUT} = 5\text{V}$	60			mA
Short Circuit Current Limit	$I_{SC}$	$V_{OUT} = \text{GND}$		80		mA
Ripple Voltage (Note1)	$V_{RIPPLE}$	$V_{IN} = 3\text{V}$ , $I_{OUT} = 60\text{mA}$ , $V_{OUT} = 5\text{V}$		60		mVp-p
		$V_{IN} = 3.3\text{V}$ , $I_{OUT} = 60\text{mA}$ , $V_{OUT} = 5.5\text{V}$		70		
Efficiency	$\eta$	$I_{OUT} = 15\text{mA}$ , $V_{IN} = 2.7\text{V}$ , $V_{OUT} = 5\text{V}$		90		%
Frequency	$f_{OSC}$	Oscillator Free Running		1.0		MHz
EN Input Threshold High	$V_{EH}$		1.3			V
EN Input Threshold Low	$V_{EL}$				0.6	V
EN Input Current	$I_{EN}$	$V_{EN} = V_{IN}$ , $V_{EN} = \text{GND}$			0.1	$\mu\text{A}$
Over Temperature Shutdown	OTS			160		$^{\circ}\text{C}$
Over Temperature Hysteresis	OTH			20		

Note 1: Effective series resistance (ESR) of capacitors is  $< 0.1\Omega$ .

## ■ Detailed Description

The BP3289 regulated charge pump provides a regulated input voltages ranging from less than the output to greater than the input. This is accomplished by automatic mode switching within the device.

## ■ Short Circuit and Thermal Protection

The BP3289 has a thermal protection and shutdown circuit that continuously monitors the IC junction temperature. If the thermal protection circuit senses the die temperature exceeding approximately 160°C, the thermal shutdown will disable the charge pump switching cycle operation. The thermal limit system has 20°C of system hysteresis before the charge pump can reset. Once the over current event is removed from the output and the junction temperature drops below 140°C, the charge pump will become active again. The thermal protection system will cycle on and off if an output short circuit condition persists. This will allow the BP3289 to operate indefinitely a short circuit condition without damage to the device.

## ■ Shutdown Mode

A control pin EN on the regulator can be used to place the device into an energy-saving shutdown mode. In this mode, the output is disconnected from the input as long as  $V_{IN}$  is greater than or equal to minimum  $V_{IN}$  and input quiescent current is reduced to 1μA maximum.

## ■ Capacitor Selection

For minimum output voltage ripple, the output capacitor  $C_{OUT}$  should be a ceramic, surface-mount type. Tantalum capacitors generally have a higher Effective Series Resistance (ESR) and may contribute to higher output voltage ripple. Leaded capacitors also increase ripple due to the higher inductance of the package itself. To achieve best operation with low input voltage and high load current, the input and pump capacitors ( $C_{IN}$ ,  $C_{PUMP}$  respectively) should also be surface-mount ceramic types. In all cases, X7R dielectric is recommended.

With light loads or higher input voltage, a smaller 0.1μF pump capacitor ( $C_{PUMP}$ ) and smaller 1μF input and output capacitor ( $C_{IN}$  and  $C_{OUT}$ , respectively) can be used. To minimize output voltage ripple, increase the output capacitor,  $C_{OUT}$ , to 10μF or larger.

## ■ Efficiency

The efficiency of the charge pump regulator varies with the output voltage version, the applied input voltage, the load current, and the internal operation mode of the device.

The approximate efficiency is given by:

$$\text{5.5V, 5V Version } (V_{IN} \leq V_{OUT}) \\ \text{Efficiency (\%)} = V_{OUT} / 2V_{IN} \cdot 100\%$$

$$\text{Others Version } (V_{IN} > V_{OUT}) \\ \text{Efficiency (\%)} = V_{OUT} / V_{IN} \cdot 100\%$$

## ■ Layout

Large ripple currents flow in the  $V_{IN}$  and  $V_{OUT}$  traces. To minimize both input and output ripple, keep the capacitors as close as possible to the regulator using short, direct circuit traces.

The trace lengths from the input and output capacitors have been kept as short as possible. A star ground system has been implemented, with GND pin as the center of the star. No ground plane is provided in other layers, as this will provide capacitive coupling for noise spikes.

# BP3289

Efficiency vs  $V_{IN}$

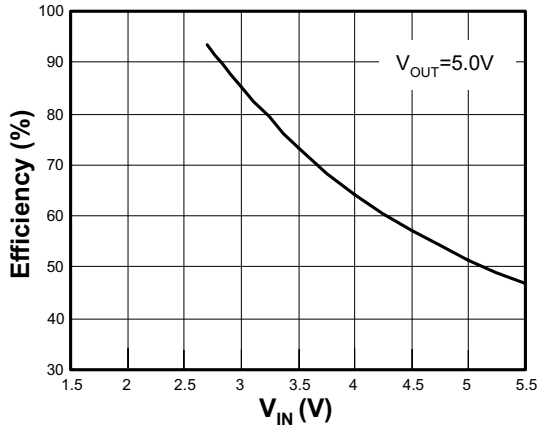

Output Voltage vs Temperature

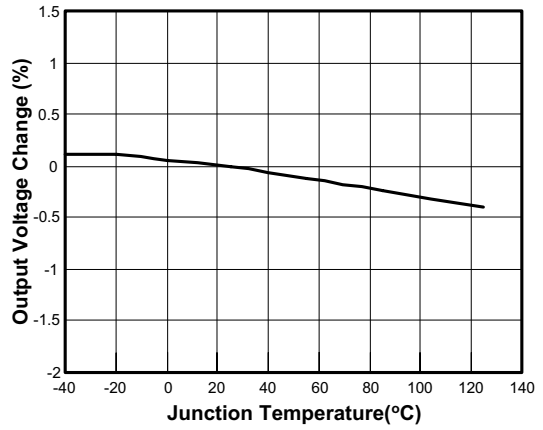

Short Circuit Current vs  $V_{IN}$

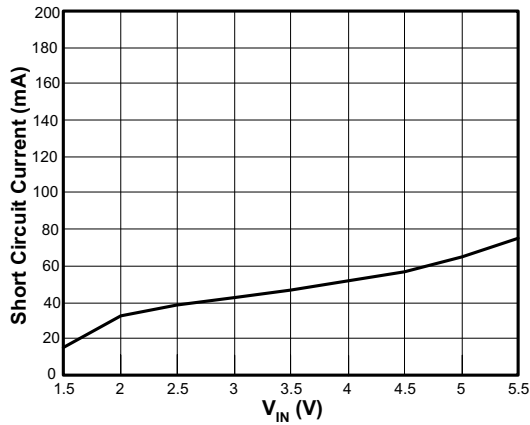

Efficiency vs Load Current

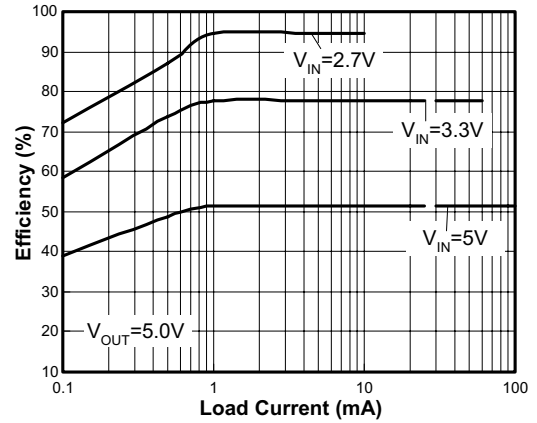

Supply Current vs Temperature (No Load)

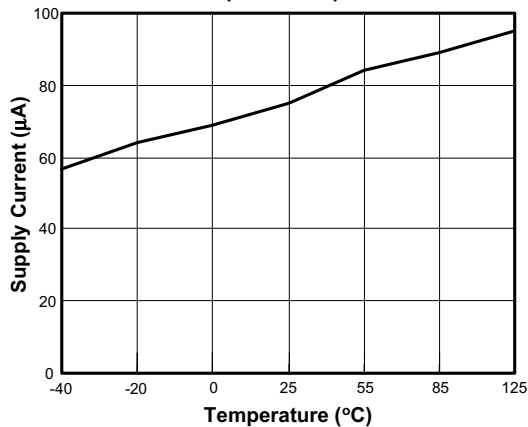

Shutdown Current vs Temperature

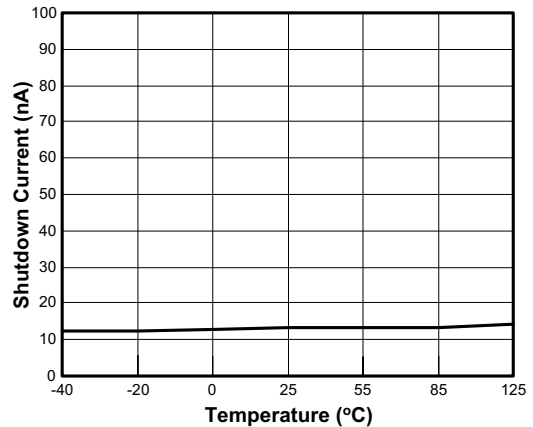

# BP3289

### Output Ripple Voltage vs $V_{IN}$

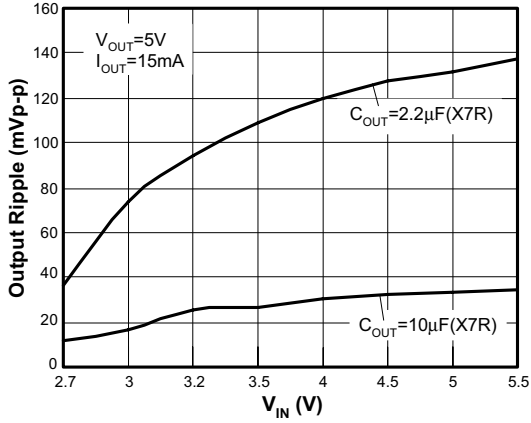

### Output Ripple Voltage vs $V_{IN}$

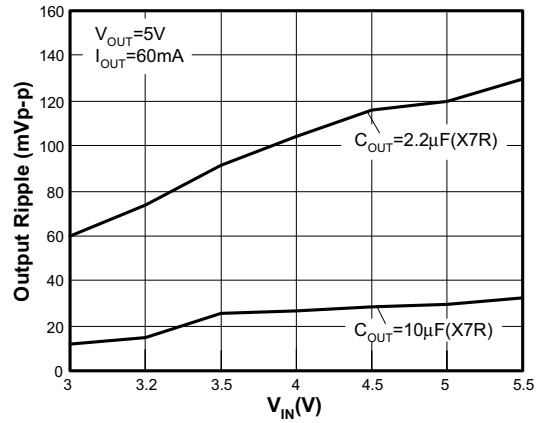

### Input Current at Turn-On

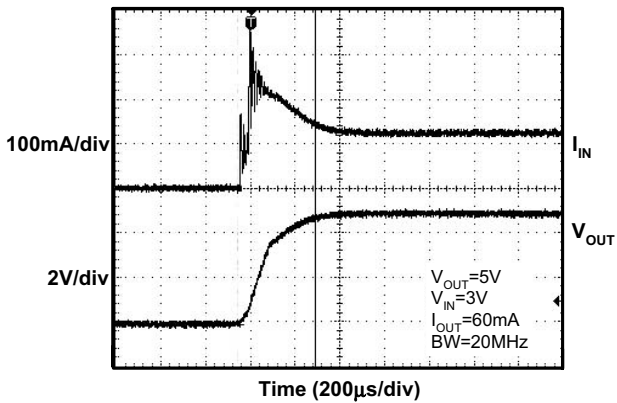

### Load Transient Response

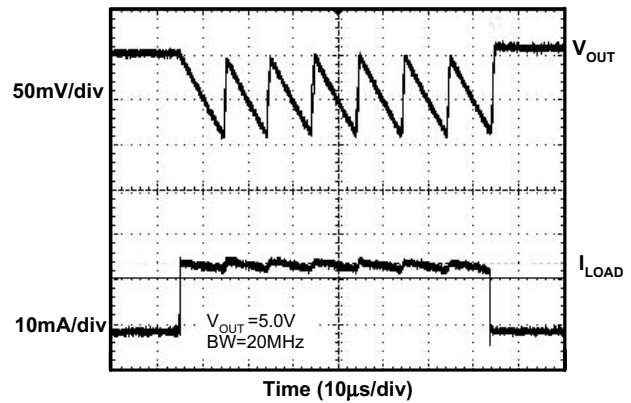

### Line Transient Response

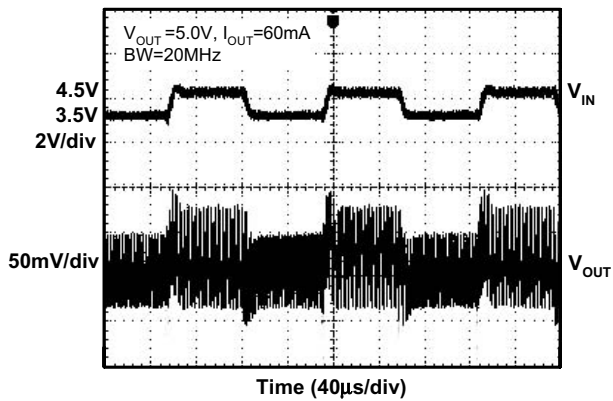



## ■ Date Code Rule

Marking			Date Code		Year
A	A	A	W	W	xxx0
A	A	A	W	<u>W</u>	xxx1
A	A	A	<u>W</u>	W	xxx2
A	A	A	<u>W</u>	<u>W</u>	xxx3
A	A	<u>A</u>	W	W	xxx4
A	A	<u>A</u>	W	<u>W</u>	xxx5
A	A	<u>A</u>	<u>W</u>	W	xxx6
A	A	<u>A</u>	<u>W</u>	<u>W</u>	xxx7
A	<u>A</u>	A	W	W	xxx8
A	<u>A</u>	A	W	<u>W</u>	xxx9

## ■ Tape & Reel Dimension

### SOT-26

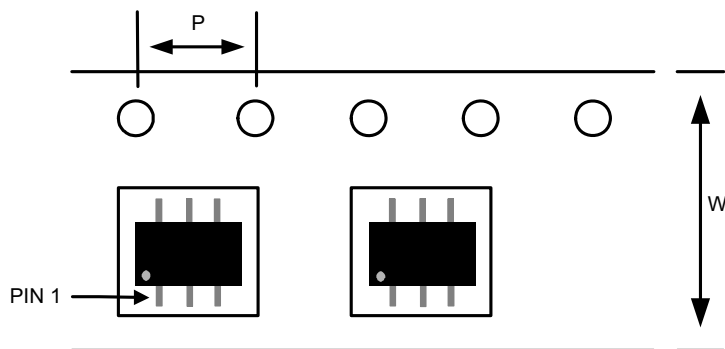

Carrier Tape, Number of Components Per Reel and Reel Size

Package	Carrier Width (W)	Pitch (P)	Part Per Full Reel	Reel Size
SOT-26	8.0±0.1 mm	4.0±0.1 mm	3000pcs	180±1 mm

# BP3289

## ■ Package Dimension

### SOT-26

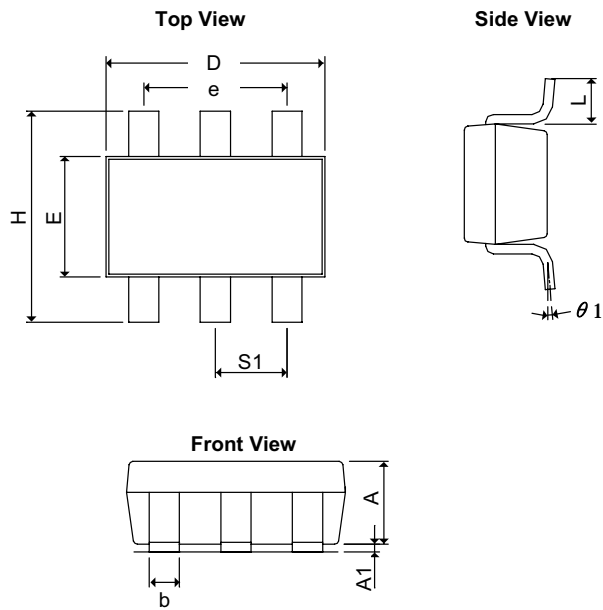

SYMBOLS	MILLIMETERS		INCHES	
	MIN	MAX	MIN	MAX
<b>A</b>	1.20REF		0.0472REF	
<b>A<sub>1</sub></b>	0.00	0.15	0.0000	0.0059
<b>b</b>	0.30	0.55	0.0118	0.0217
<b>D</b>	2.70	3.10	0.1063	0.1220
<b>E</b>	1.40	1.80	0.0551	0.0709
<b>e</b>	1.90 BSC		0.0748 BSC	
<b>H</b>	2.60	3.00	0.10236	0.11811
<b>L</b>	0.37REF		0.0146REF	
<b><math>\theta 1</math></b>	0°	10°	0°	10°
<b>S<sub>1</sub></b>	0.95REF		0.0374REF	