

BV <sub>DSS</sub>	30 V
R <sub>DS(ON)</sub>	13mΩ
I <sub>D</sub>	54A

**N-CHANNEL ENHANCEMENT MODE POWER MOSFET**
**Description**

The BP140N provide the designer with the best combination of fast switching, ruggedized device design, low on-resistance and cost-effectiveness.

The TO-252 package is universally preferred for all commercial-industrial surface mount applications and suited for low voltage applications such as DC/DC converters.

**Features**

- \*Simple Drive Requirement
- \*Low Gate Charge
- \*Fast Switching

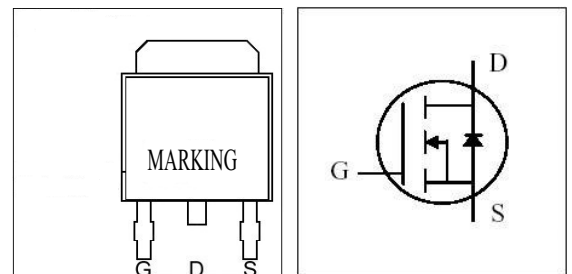
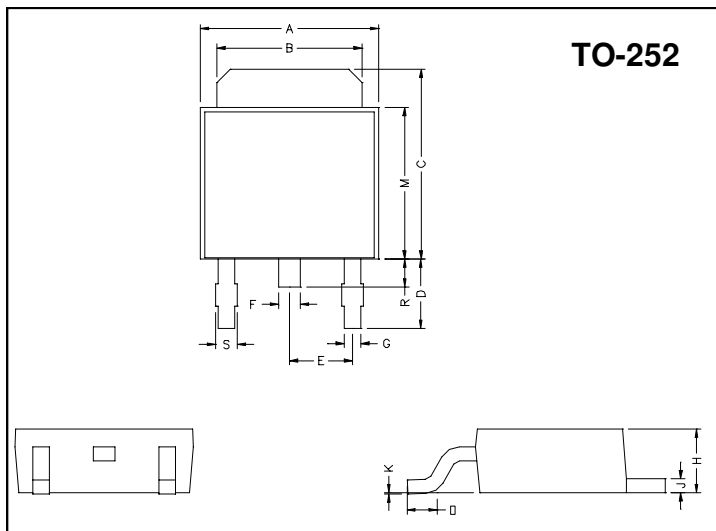
**Package Dimensions**

REF.	Millimeter		REF.	Millimeter	
	Min.	Max.		Min.	Max.
A	6.40	6.80	G	0.50	0.70
B	5.20	5.50	H	2.20	2.40
C	6.80	7.20	J	0.45	0.55
D	2.40	3.00	K	0	0.15
E	2.30 REF.		L	0.90	1.50
F	0.70	0.90	M	5.40	5.80
S	0.60	0.90	R	0.80	1.20

**Absolute Maximum Ratings**

Parameter	Symbol	Ratings	Unit
Drain-Source Voltage	V <sub>DS</sub>	30	V
Gate-Source Voltage	V <sub>GS</sub>	±20	V
Continuous Drain Current, V <sub>GS</sub> @10V	I <sub>D</sub> @T <sub>C</sub> =25°C	54	A
Continuous Drain Current, V <sub>GS</sub> @10V	I <sub>D</sub> @T <sub>C</sub> =100°C	32	A
Pulsed Drain Current <sup>1</sup>	I <sub>DM</sub>	150	A
Total Power Dissipation	P <sub>D</sub> @T <sub>C</sub> =25°C	62.5	W
Linear Derating Factor		0.5	W/°C
Operating Junction and Storage Temperature Range	T <sub>j</sub> , T <sub>stg</sub>	-55 ~ +150	°C

**Thermal Data**

Parameter	Symbol	Value	Unit
Thermal Resistance Junction-case Max.	R <sub>thj-c</sub>	2.0	°C/W
Thermal Resistance Junction-ambient Max.	R <sub>thj-a</sub>	110	°C/W

## Electrical Characteristics (T<sub>j</sub> = 25°C unless otherwise specified)

Parameter	Symbol	Min.	Typ.	Max.	Unit	Test Conditions
Drain-Source Breakdown Voltage	BV <sub>DSS</sub>	25	-	-	V	V <sub>GS</sub> =0, I <sub>D</sub> =250uA
Breakdown Voltage Temperature Coefficient	ΔBV <sub>DSS</sub> /ΔT <sub>j</sub>	-	0.037	-	V/°C	Reference to 25°C, I <sub>D</sub> =1mA
Gate Threshold Voltage	V <sub>GS(th)</sub>	1.0	-	3.0	V	V <sub>DS</sub> =V <sub>GS</sub> , I <sub>D</sub> =250uA
Forward Transconductance	g <sub>fs</sub>	-	15.6	-	S	V <sub>DS</sub> =10V, I <sub>D</sub> =25A
Gate-Source Leakage Current	I <sub>GSS</sub>	-	-	±100	nA	V <sub>GS</sub> = ±20V
Drain-Source Leakage Current(T <sub>j</sub> =25°C)	I <sub>DSS</sub>	-	-	1	uA	V <sub>DS</sub> =30V, V <sub>GS</sub> =0
Drain-Source Leakage Current(T <sub>j</sub> =150°C)		-	-	25	uA	V <sub>DS</sub> =20V, V <sub>GS</sub> =0
Static Drain-Source On-Resistance	R <sub>DS(ON)</sub>	-	-	13	m	V <sub>GS</sub> =10V, I <sub>D</sub> =25A
		-	-	16		V <sub>GS</sub> =4.5V, I <sub>D</sub> =20A
Total Gate Charge <sup>2</sup>	Q <sub>g</sub>	-	21	-	nC	I <sub>D</sub> =25A V <sub>DS</sub> =20V V <sub>GS</sub> =5V
Gate-Source Charge	Q <sub>gs</sub>	-	2.8	-		
Gate-Drain ("Miller") Charge	Q <sub>gd</sub>	-	16	-		
Turn-on Delay Time <sup>2</sup>	T <sub>d(on)</sub>	-	8	-	ns	V <sub>DS</sub> =15V I <sub>D</sub> =20A V <sub>GS</sub> =10V R <sub>G</sub> =3.3 R <sub>D</sub> =0.75
Rise Time	T <sub>r</sub>	-	75	-		
Turn-off Delay Time	T <sub>d(off)</sub>	-	22	-		
Fall Time	T <sub>f</sub>	-	20	-		
Input Capacitance	C <sub>iss</sub>	-	605	-	pF	V <sub>GS</sub> =0V V <sub>DS</sub> =25V f=1.0MHz
Output Capacitance	C <sub>oss</sub>	-	415	-		
Reverse Transfer Capacitance	C <sub>rss</sub>	-	195	-		

## Source-Drain Diode

Parameter	Symbol	Min.	Typ.	Max.	Unit	Test Conditions
Forward On Voltage <sup>2</sup>	V <sub>SD</sub>	-	-	1.26	V	I <sub>S</sub> =50A, V <sub>GS</sub> =0V, T <sub>j</sub> =25°C
Continuous Source Current (Body Diode)	I <sub>S</sub>	-	-	50	A	V <sub>D</sub> =V <sub>G</sub> =0V, V <sub>S</sub> =1.26V
Pulsed Source Current (Body Diode) <sup>1</sup>	I <sub>SM</sub>	-	-	150	A	

## Drain-Source Avalanche Ratings

Parameter	Symbol	Min.	Typ.	Max.	Unit	Test Conditions
Single Pulse Avalanche Energy <sup>2</sup>	E <sub>AS</sub>	-	-	61	mJ	V <sub>DD</sub> =25V, I <sub>D</sub> =35A, L=100uH
Avalanche Current	I <sub>AR</sub>	-	-	35	A	V <sub>GS</sub> =10V,

Notes: 1. Pulse width limited by safe operating area.

2. Pulse width ≤ 300us, duty cycle ≤ 2%.

## Characteristics Curve

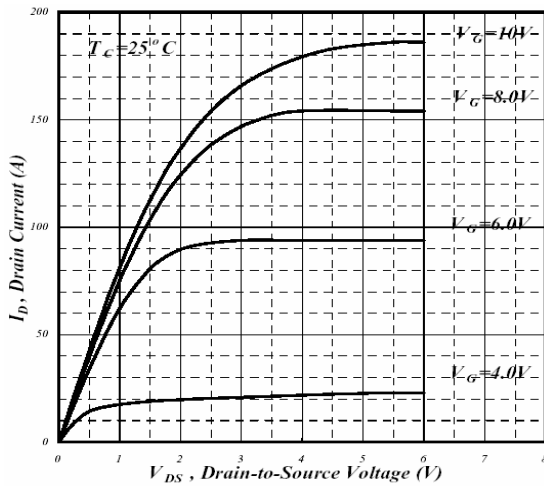

Fig 1. Typical Output Characteristics

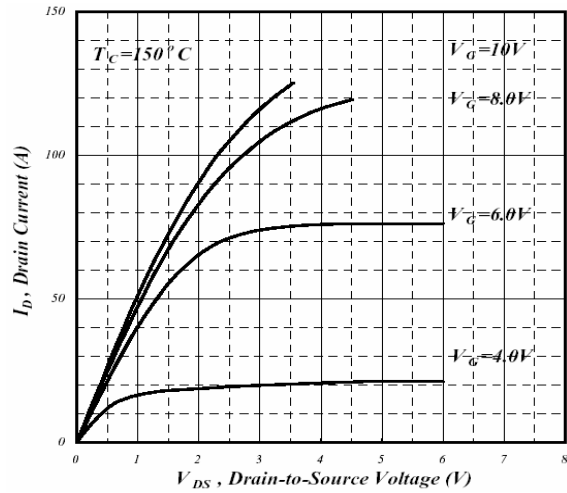

Fig 2. Typical Output Characteristics

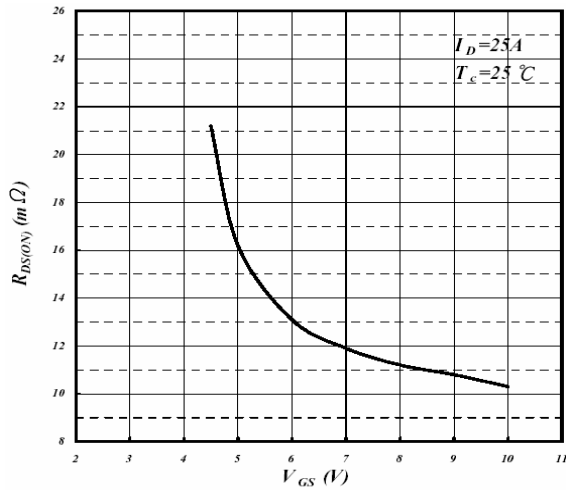

Fig 3. On-Resistance v.s. Gate Voltage

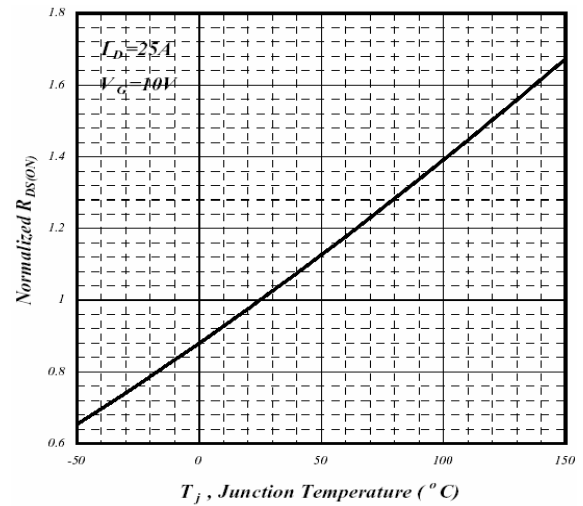

Fig 4. Normalized On-Resistance v.s. Junction Temperature

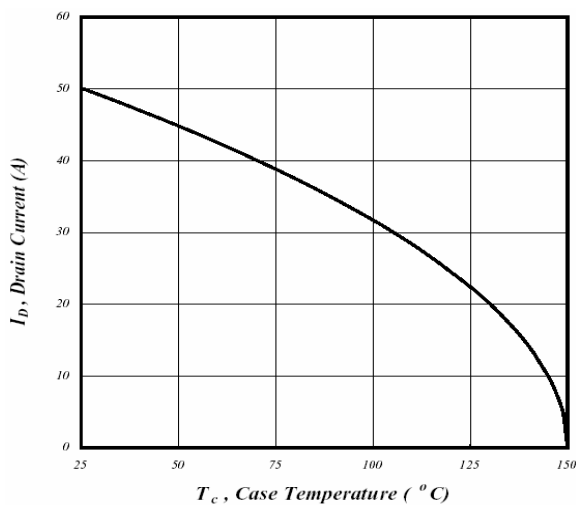

Fig 5. Maximum Drain Current v.s. Case Temperature

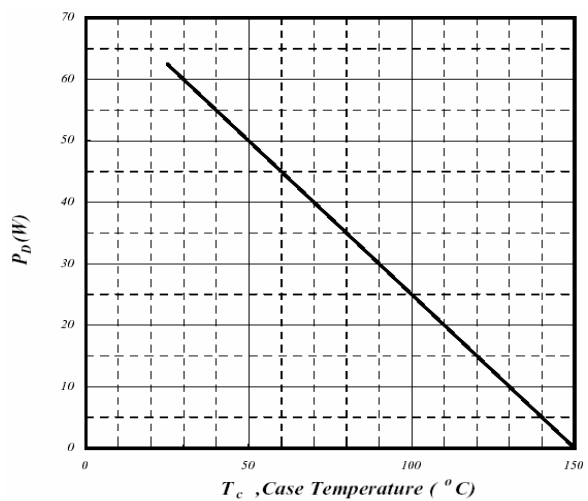
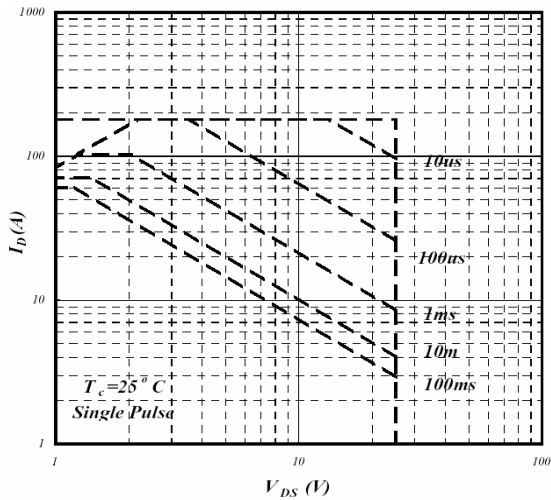
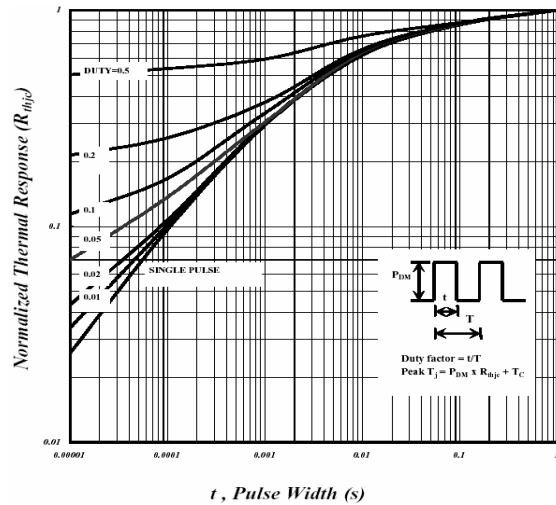

Fig 6. Type Power Dissipation



**Fig 7. Maximum Safe Operating Area**



**Fig 8. Effective Transient Thermal Impedance**

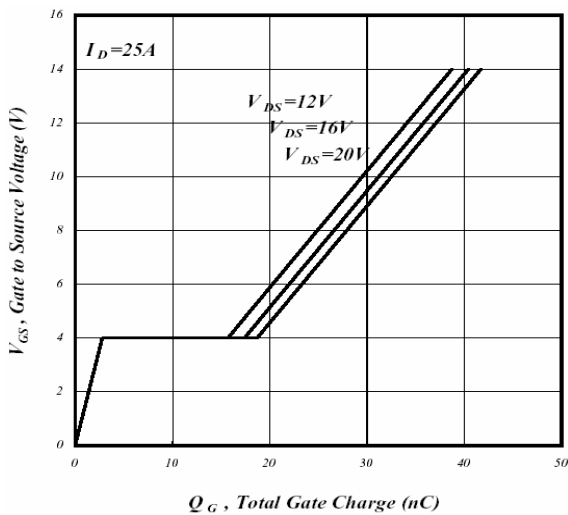

**Fig 9. Gate Charge Characteristics**

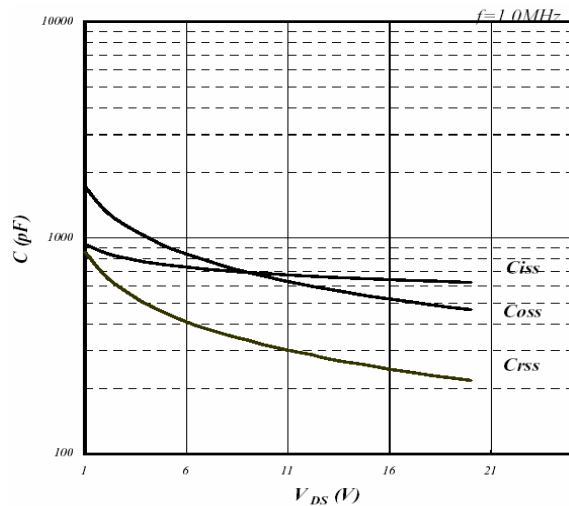

**Fig 10. Typical Capacitance Characteristics**

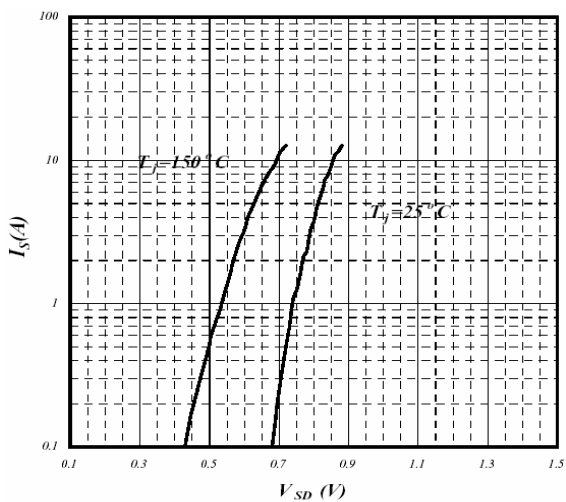

**Fig 11. Forward Characteristics of Reverse Diode**

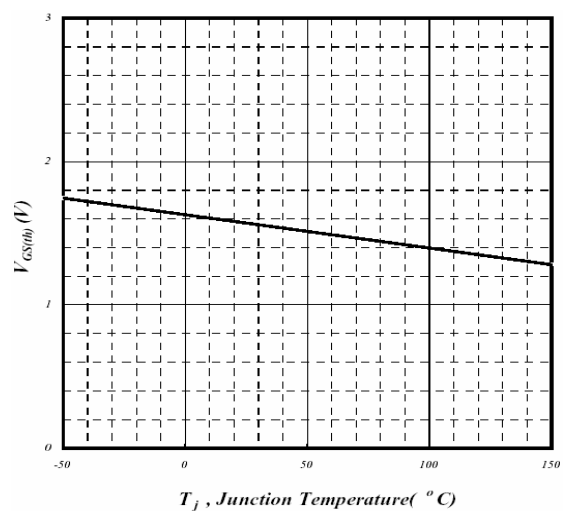

**Fig 12. Gate Threshold Voltage v.s. Junction Temperature**

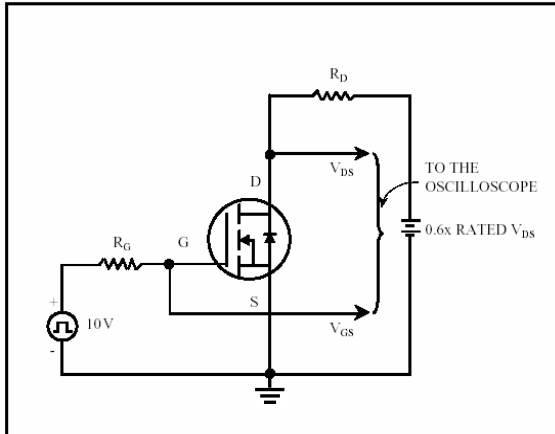

**Fig 13. Switching Time Circuit**

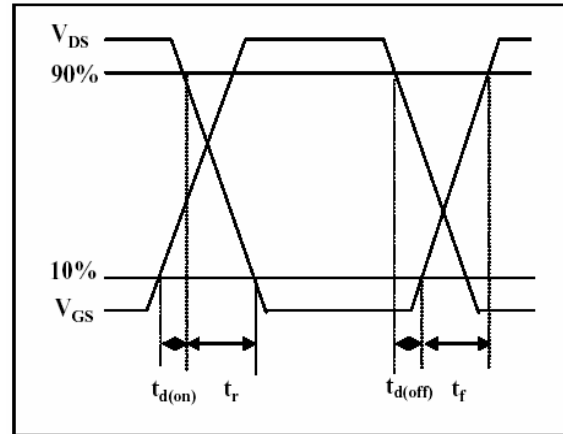

**Fig 14. Switching Time Waveform**

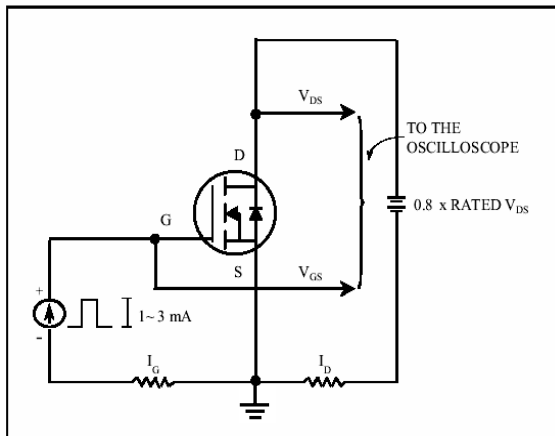

**Fig 15. Gate Charge Circuit**

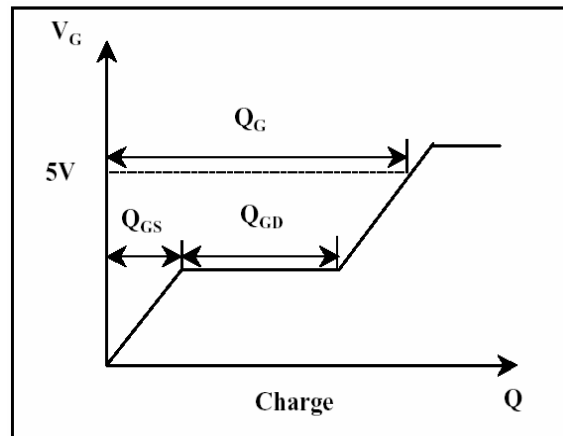

**Fig 16. Gate Charge Waveform**