

N-Channel MOSFET

BV _{DSS}	500V
R _{DS(ON)}	1.2Ω
I _D	5A

Features

- * Very Low leakage current
- * Low gate charge
- * Avalanche ratings
- * High speed switching
- * Lower R_{DS(ON)}

Package Dimensions

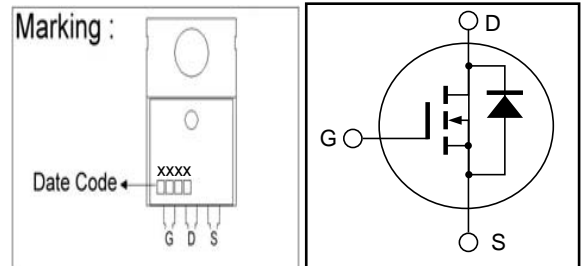
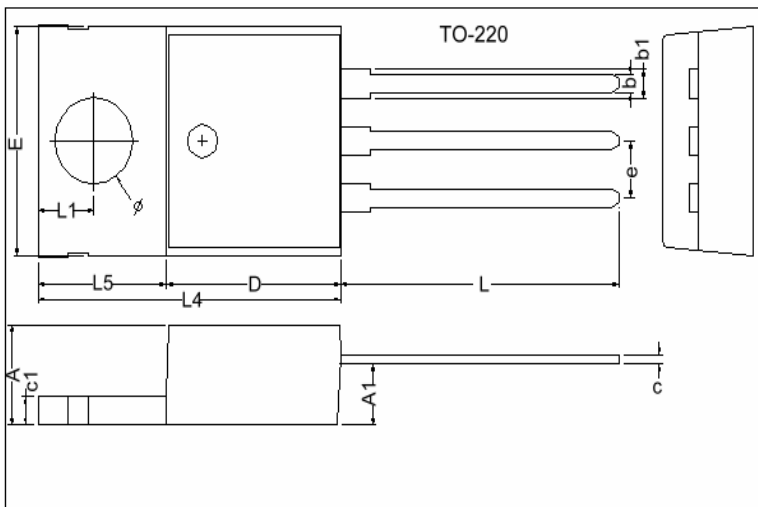

REF.	Millimeter		REF.	Millimeter	
	Min.	Max.		Min.	Max.
A	4.40	4.80	c1	1.25	1.45
b	0.76	1.00	b1	1.17	1.47
c	0.36	0.50	L	13.25	14.25
D	8.60	9.00	e	2.54 REF.	
E	9.80	10.4	L1	2.60	2.89
L4	14.7	15.3	∅	3.71	3.96
L5	6.20	6.60	A1	2.60	2.80

Absolute Maximum Ratings (Ta = 25°C)

Item	Symbol	Ratings	Unit
Drain to source voltage	V _{DSS}	500	V
Gate to source voltage	V _{GSS}	±30	V
Drain current	I _D	5	A
Drain peak current	I _{D(pulse)} ^{Note1}	20	A
Body-drain diode reverse drain current	I _{DR}	5	A
Body-drain diode reverse drain peak current	I _{DR(pulse)} ^{Note1}	20	A
Avalanche current	I _{AP} ^{Note3}	5	A
Channel dissipation	P _{ch} ^{Note2}	40	W
Channel to case Thermal Impedance	θ _{ch-c}	4.17	°C/W
Channel temperature	T _{ch}	150	°C
Storage temperature	T _{stg}	-55 to +150	°C

- Note: 1. PW ≤ 10μs, duty cycle ≤ 1 %
 2. Value at T_c = 25°C
 3. T_{ch} ≤ 150°C

Electrical Characteristics (Ta = 25°C)

Item	Symbol	Min	Typ	Max	Unit	Test Conditions
Drain to source breakdown voltage	$V_{(BR)DSS}$	500	—	—	V	$I_D = 10\text{mA}, V_{GS} = 0$
Gate to source leak current	I_{GSS}	—	—	± 0.1	μA	$V_{GS} = \pm 30\text{V}, V_{DS} = 0$
Zero gate voltage drain current	I_{DSS}	—	—	1	μA	$V_{DS} = 500\text{V}, V_{GS} = 0$
Gate to source cutoff voltage	$V_{GS(off)}$	3.0	—	4.0	V	$I_D = 1\text{mA}, V_{DS} = 10\text{V}$
Static drain to source on state resistance	$R_{DS(on)}$	—	1.2	1.5	Ω	$I_D = 2.5\text{A}, V_{GS} = 10\text{V}^{\text{Note4}}$
Forward transfer admittance	$ y_{fs} $	3.0	4.5	—	S	$I_D = 2.5\text{A}, V_{DS} = 10\text{V}^{\text{Note4}}$
Input capacitance	C_{iss}	—	580	—	pF	$V_{DS} = 25\text{V}$
Output capacitance	C_{oss}	—	70	—	pF	$V_{GS} = 0$
Reverse transfer capacitance	C_{rss}	—	13	—	pF	$f = 1\text{MHz}$
Turn-on delay time	$t_{d(on)}$	—	20	—	ns	$I_D = 2.5\text{A}$
Rise time	t_r	—	15	—	ns	$V_{GS} = 10\text{V}$
Turn-off delay time	$t_{d(off)}$	—	65	—	ns	$R_L = 100\Omega$
Fall time	t_f	—	15	—	ns	$R_g = 10\Omega$
Total gate charge	Q_g	—	15	—	nC	$V_{DD} = 400\text{V}$
Gate to source charge	Q_{gs}	—	3	—	nC	$V_{GS} = 10\text{V}$
Gate to drain charge	Q_{gd}	—	8	—	nC	$I_D = 5\text{A}$
Body-drain diode forward voltage	V_{DF}	—	0.85	1.3	V	$I_F = 5\text{A}, V_{GS} = 0$
Body-drain diode reverse recovery time	t_{rr}	—	400	—	ns	$I_F = 5\text{A}, V_{GS} = 0$ $diF/dt = 100\text{A}/\mu\text{s}$
Body-drain diode reverse recovery charge	Q_{rr}	—	1.5	—	μC	

Note: 4. Pulse test

Main Characteristics

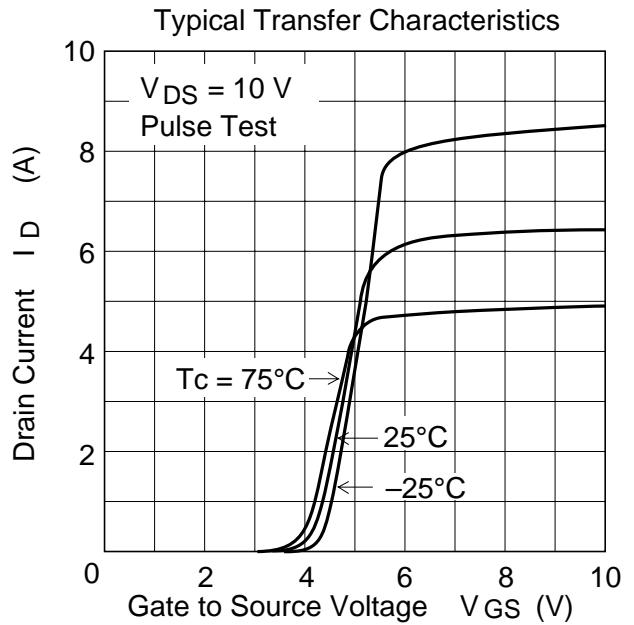
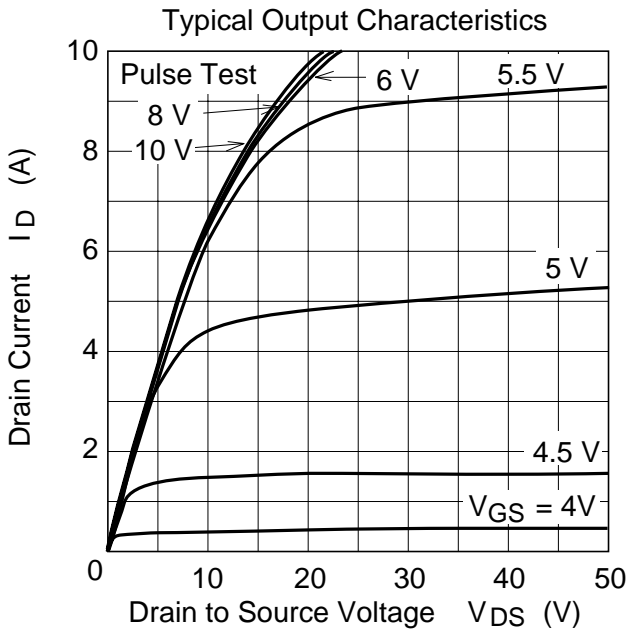
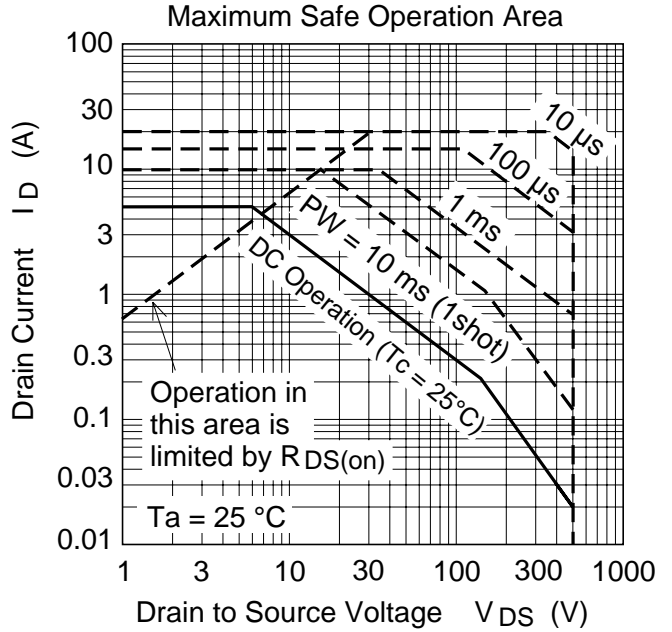
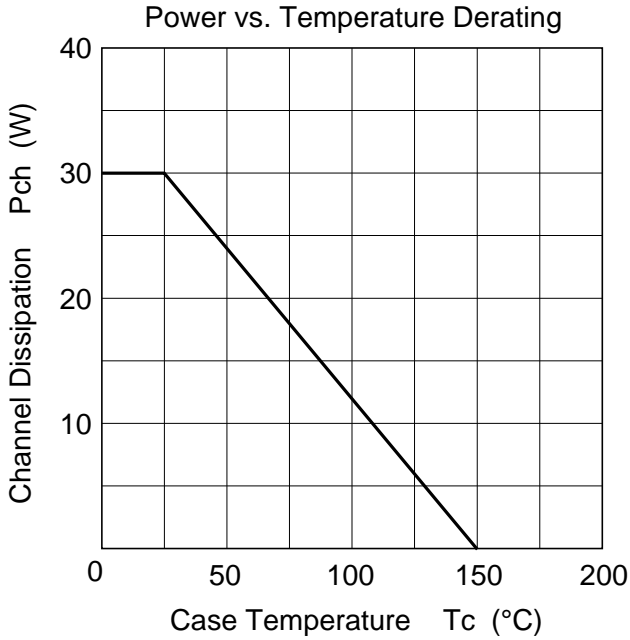

Drain to Source Saturation Voltage vs. Gate to Source Voltage

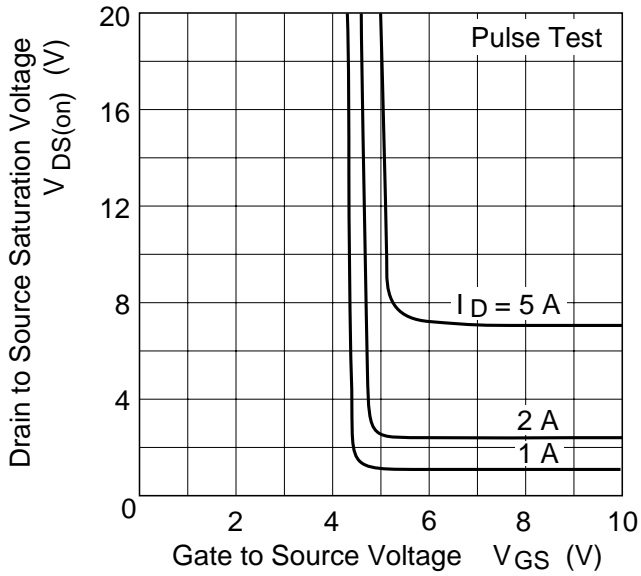

Static Drain to Source on State Resistance vs. Drain Current

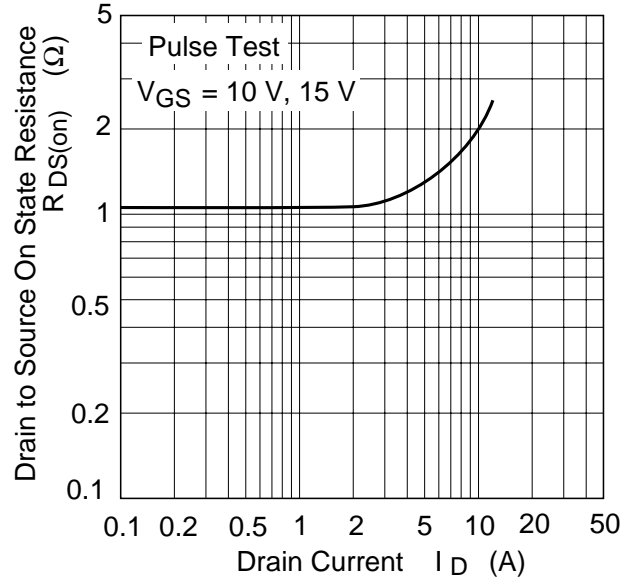

Static Drain to Source on State Resistance vs. Temperature

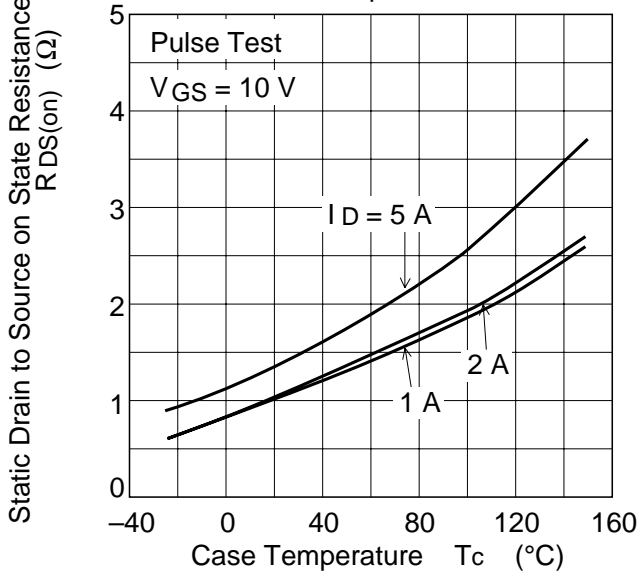

Forward Transfer Admittance vs. Drain Current

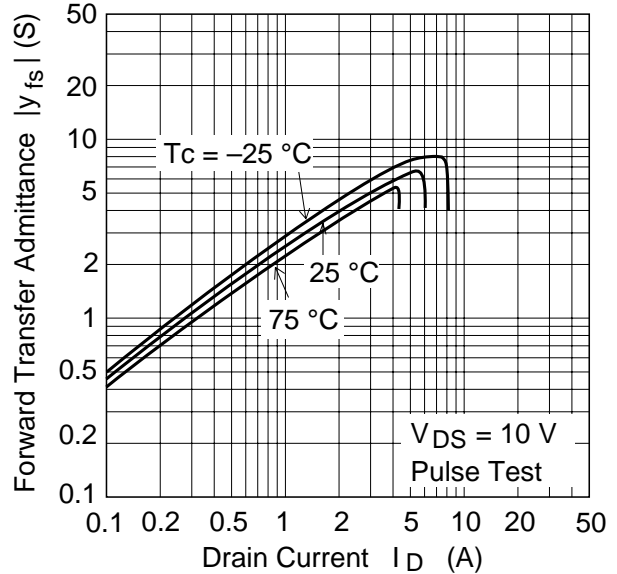

Body-Drain Diode Reverse Recovery Time

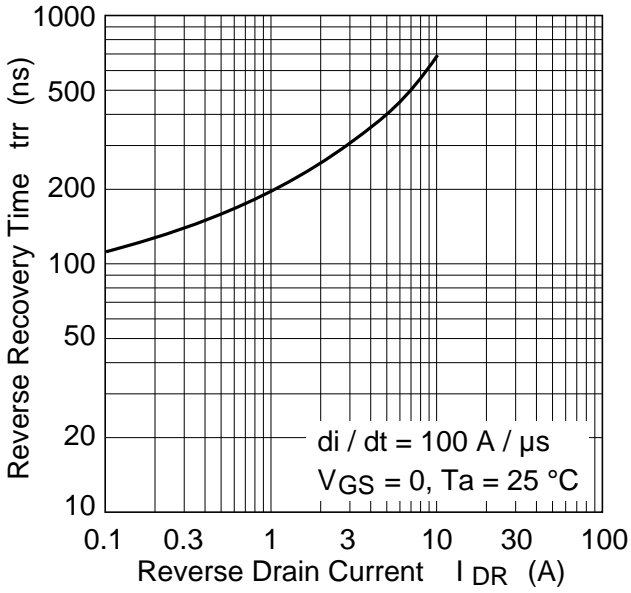

Typical Capacitance vs. Drain to Source Voltage

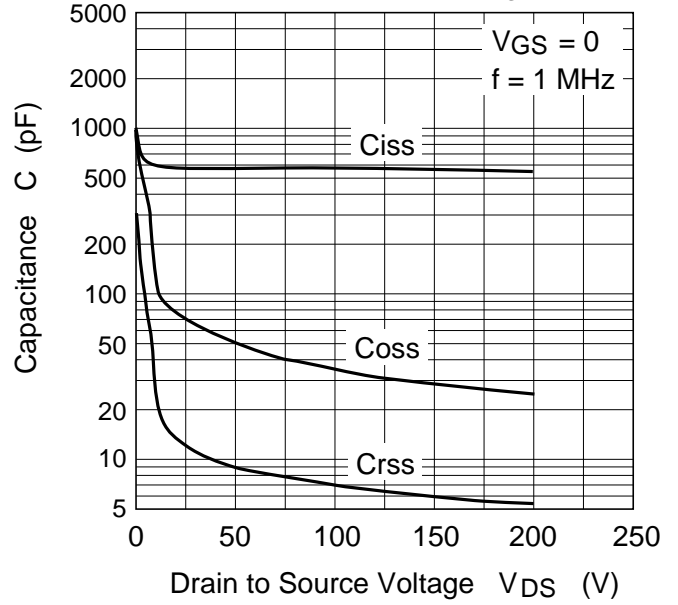

Dynamic Input Characteristics

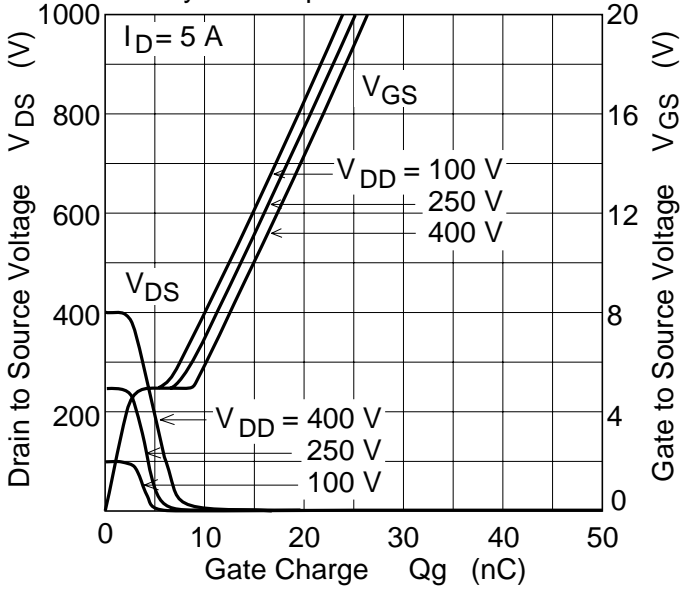

Switching Characteristics

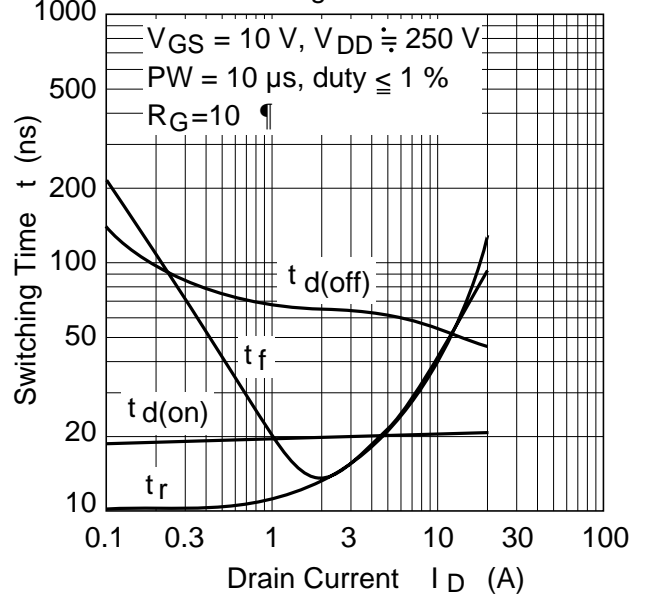

Reverse Drain Current vs. Source to Drain Voltage

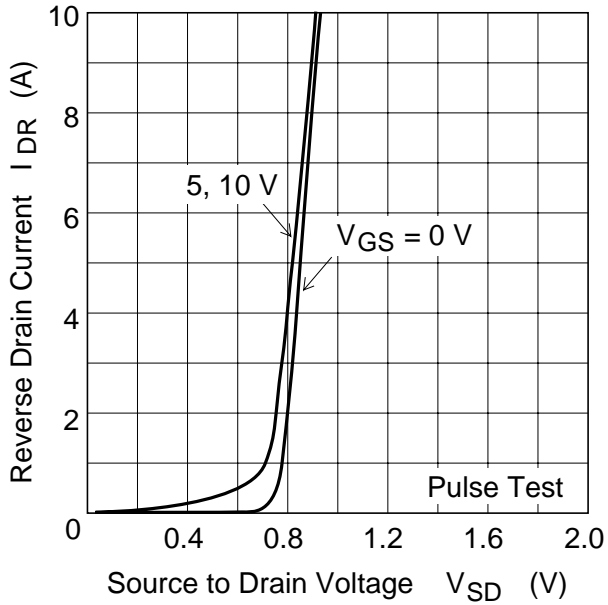

Gate to Source Cutoff Voltage vs. Case Temperature

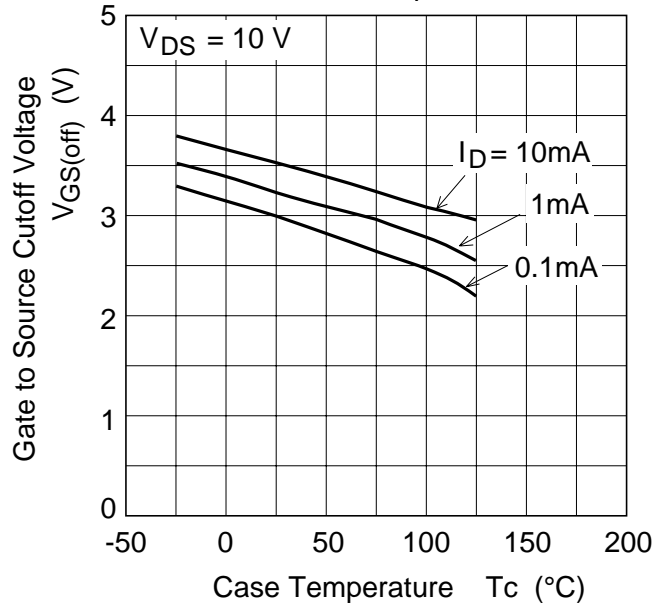

Switching Time Test Circuit

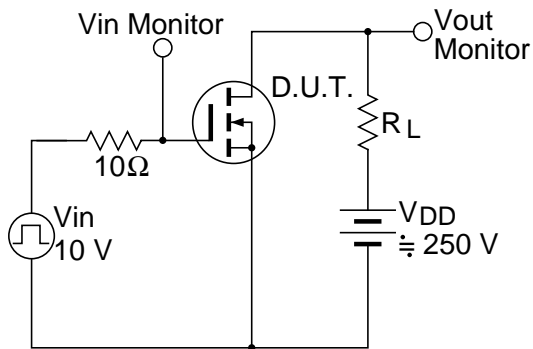

Waveform

